

Single Phase Simplex

SJE Rhombus® Type 112

Installation Instructions and Operation/Troubleshooting Manual



Warranty void if panel is modified.

Call factory with servicing questions:

1-800-RHOMBUS
(1-800-746-6287)

Manufactured by:



SJE RHOMBUS®

Technical support: +1-800-746-6287
techsupport@sjeinc.com
www.sjrhombus.com

PN 1008704F 05/19
© 2019 SJE, Inc. All Rights Reserved.
SJE RHOMBUS is a trademark of SJE, Inc.

This control panel must be installed and serviced by a licensed electrician in accordance with the National Electric Code NFPA-70, state and local electrical codes.

All conduit running from the sump or tank to the control panel must be sealed with conduit sealant to prevent moisture or gases from entering the panel. **NEMA 1 enclosures are for indoor use only**, primarily to provide a degree of protection against contact with enclosed equipment. Cable connectors are not required to be liquid-tight in NEMA 1 enclosures. **Do not use NEMA 1 enclosures if subjected to rain, splashing water or hose-directed water. NEMA 4X enclosures are for indoor or outdoor use**, primarily to provide a degree of protection against corrosion, wind-blown dust and rain, splashing water and hose-directed water. **Cable connectors must be liquid-tight in NEMA 4X enclosures.**

Installation

A standard Type 112 panel is designed to operate with three floats. These floats operate pump stop, pump start, and high level alarm functions.

NOTE: Options ordered may affect the number of floats and their functions. Please reference the schematic provided with the control panel for proper installation.

Installation of Floats

CAUTION: If control switch cables are not wired and mounted in the correct order, the pump system will not function properly.

WARNING: Turn off all power before installing floats in pump chamber. Failure to do so could result in serious or fatal electrical shock.

1. Use float label kit to label floats for specific operation (stop, start, alarm, etc.). See schematic for float options.
2. Determine your normal operating level, as illustrated in **Figure 1**.
3. Mount float switches at appropriate levels as illustrated in **Figures 2-4**. Be sure that floats have free range of motion without touching each other or other equipment in the basin.

If using the mounting clamp; follow steps 4-6.

4. Place the cord into the clamp as shown in **Figure 2**.
5. Locate the clamp at the desired activation level and secure the clamp to the discharge pipe as shown in **Figure 2**.

NOTE: Do not install cord under hose clamp.

6. Tighten the hose clamp using a screwdriver. Over tightening may result in damage to the plastic clamp. Make sure the float cable is not allowed to touch the excess hose clamp band during operation.

NOTE: All hose clamp components are made of 18-8 stainless steel material. See your SJE Rhombus® supplier for replacements.

Installation Instructions

Mounting the Control Panel

1. Determine mounting location for panel. If distance exceeds the length of either the float switch cables or the pump power cables, splicing will be required. For outdoor or wet installation, we recommend the use of an SJE Rhombus® liquid-tight junction box with liquid-tight connectors to make required connections. **You must use conduit sealant to prevent moisture or gases from entering the panel.**
2. Mount control panel (mounting flanges are furnished with control panel).
3. Determine conduit entrance locations on control panel. Check local codes and schematic for the number of power circuits required.

NOTE: Be sure the proper power supply voltage, and phase are the same as the pump motor being installed. If in doubt, see the pump identification plate for electrical requirements.

4. Drill proper size holes for type of connectors being used.

NOTE: If using conduit, be sure that it is of adequate size to pull the pump and switch cables through. **You must use conduit sealant to prevent moisture or gases from entering the panel.**

5. Attach cable connectors and/or conduit connectors to control panel.

**FOR INSTALLATION WITHOUT A SPLICE,
GO TO STEP 11;
FOR INSTALLATION REQUIRING
A SPLICE, FOLLOW STEPS 6-10.**

6. Determine location for mounting junction box according to local code requirements. **Do not** mount the junction box inside the sump or basin.
7. Mount junction box to proper support.
8. Run conduit to junction box. Drill proper size holes for the type of conduit used. Attach liquid-tight connectors to junction box.

9. Identify and label each wire before pulling through conduit into control panel and junction box. Pull pump power cables and control switch cables through connectors into junction box. Make wire splice connections at junction box.
10. Firmly tighten all fittings on junction box. Insure all cable connectors are liquid-tight and sealed.
11. If a junction box is not required, identify and label cables on both float and stripped ends.
12. Connect pump and float wires to proper position on terminals. See schematic inside control panel for terminal layouts.
13. Connect control, alarm and pump power conductors to proper position on terminals. See schematic inside control panel for terminal connections.

NOTE: It is the recommendation of the factory to use separate pump and control/alarm power sources.

**VERIFY CORRECT OPERATION OF CONTROL PANEL
AFTER INSTALLATION IS COMPLETE.**

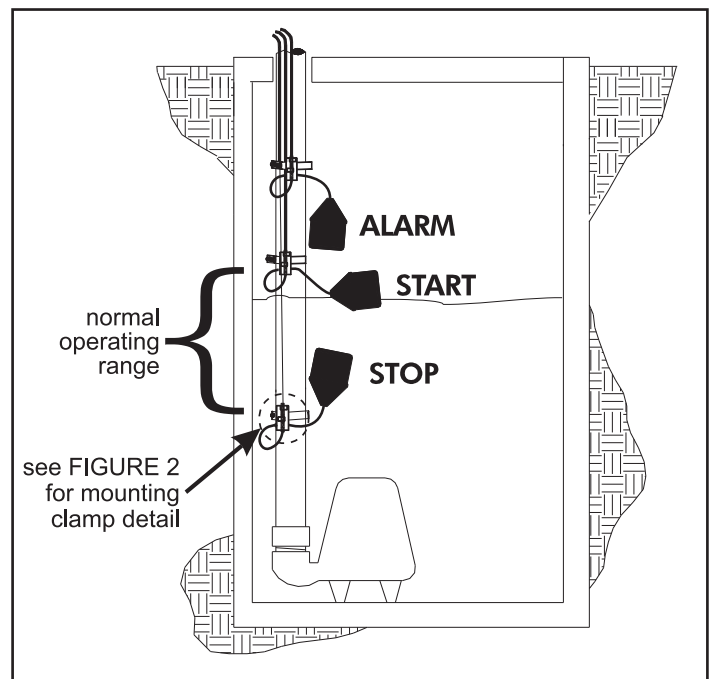

FIGURE 1
Three float simplex - pump down installation

Installation Instructions

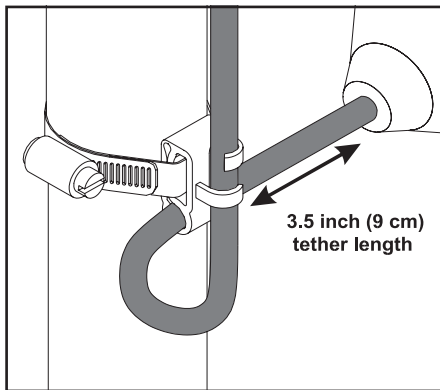

FIGURE 2
Mounting clamp detail

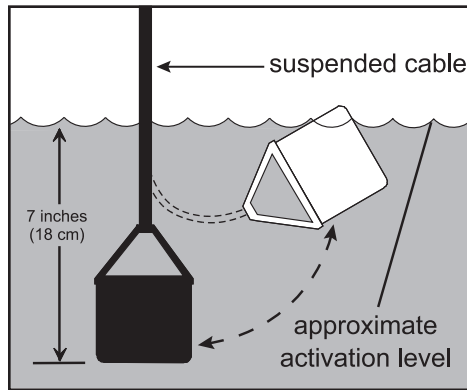

FIGURE 3
Internally weighted float

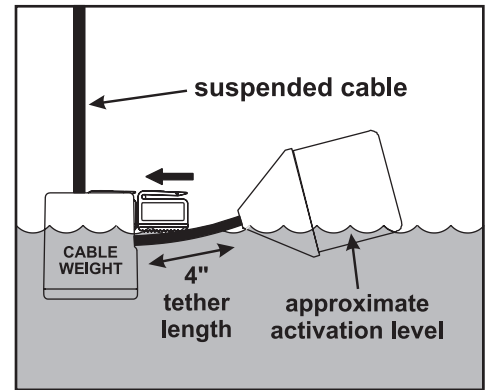

FIGURE 4
Float with cable weight

Operations

SJE Rhombus® Type 112 control panels are designed to operate in a three float system as standard. When all floats are in the open or OFF position, the panel is inactive. As the liquid level changes and closes the stop float, the panel remains inactive until the start float also closes. At this point the pump will start, providing the HOA switch is in the AUTOMATIC mode and the power is ON. The pump will remain ON until both the stop and start floats open (return to the OFF position). If the liquid level travels beyond both the stop and start floats and reaches the alarm float, the alarm will be activated. The alarm horn can be silenced by moving the test/normal/silence switch to the silence position.

Alarm System (Horn and Indicator)

When an alarm condition occurs, a red light and horn will be activated. If the test/normal/silence switch is moved to the silence position, the horn will be silenced. When the alarm condition is cleared, the alarm system is reset. The alarm system can be tested by moving the test/normal/silence switch to the test position.

HOA Switch

A hand-off-automatic switch is provided for the pump. In the hand mode, the pump will turn on unless other safety features are employed. In the automatic mode, the pump will turn on from commands by the float switches.

Pump Run Light

The run light will be ON in either the hand or the automatic mode when the pump is called to run.

Circuit Breaker (optional)

The pump circuit has a thermal-magnetic circuit breaker which provides pump disconnect and branch circuit protection.

Dry Auxiliary Contacts (optional)

Normally open - Contacts are open under normal conditions and closed when alarm condition is present.

Normally closed - Contacts are closed under normal conditions and open when alarm condition is present. Both types automatically reset once alarm condition is cleared.

NOTE: Some options ordered may not be included in this manual.

For information regarding the operations of options not listed here or servicing questions, please call a SJE Rhombus® customer service technician at

1-800-RHOMBUS
(1-800-746-6287)

Warranty void if panel is modified.

Troubleshooting

Alarm Horn

Moving the test/normal/silence switch to the test position or activating the alarm float should turn on the alarm horn. If the horn does not sound, replace horn with same type.



Alarm Light

Moving the test/normal/silence switch to the test position or activating the alarm float should turn on the alarm light. If the light does not activate, replace with same type.

Circuit Breaker (optional)

Check each pole of the circuit breaker for proper resistance reading using the following procedure.

WARNING: Disconnect incoming power to panel.

1. Isolate the circuit breaker by disconnecting either line side or load side wires.
2. Place the ohmmeter leads across the corresponding line and load terminals of each pole.
3. With the ohmmeter on the R X 1 scale and the breaker in the OFF position, the reading should be infinity (very high resistance). With the breaker in the ON position, the reading should be nearly zero ohms (very low resistance). If the readings are not as stated, replace the circuit breaker with one of the same ratings.

NOTE: Readings may vary slightly depending on the accuracy of the measuring device.

Float Controls

Check the floats during their entire range of operation. Clean, adjust, or replace damaged floats.

Checking the float resistance - The float resistance can be measured to determine if the float is operating correctly or is defective. Use the following procedure to measure the float resistance.

WARNING: Disconnect incoming power to panel.

1. Isolate the float by disconnecting one or both of the float leads from the float terminals.
2. Place one ohmmeter lead on one of the float wires, and the other ohmmeter lead on the other float wire.
3. Place the ohmmeter dial to read ohms and place on the R X 1 scale. With the float in the "off" position, the scale should read infinity (high resistance). Replace the float if you do not get this reading. With the float in the ON position, the scale should read nearly zero (very low resistance). Replace the float if you do not get this reading.

NOTE: Readings may vary depending on the length of wire and accuracy of the measuring device.

Fuses

Check the continuity of the fuse. With power OFF, pull the fuse out of the fuse block. With the ohmmeter on the R X 1 scale, measure resistance. A reading of infinity indicates a blown fuse and must be replaced. Replace fuse with same type, voltage and amp rating.

Magnetic Contactor Coil

WARNING: Disconnect incoming power to panel.

Check the coil by disconnecting one of the coil leads. Measure the coil resistance by setting the ohmmeter on the R X 1 scale. A defective coil will read zero or infinity, indicating a short or opened coil respectively. Replace defective contactor with same type.

NOTE: Readings may vary depending on the accuracy of the measuring device.

SJE Rhombus® Five-Year Limited Warranty

For complete terms and conditions, please visit www.sjrhombus.com.

NOTICE!

Products returned must be cleaned, sanitized, or decontaminated as necessary prior to shipment to ensure that employees will not be exposed to health hazards in handling said material. All applicable laws and regulations shall apply.